

Miele

Installation plan

Washing machine



PWM 507 DV/DP
PWM 507 Hygiene/Special

To avoid the risk of accidents or damage to the machine, it is **essential** to read operating and installation instructions before installation and commissioning. This prevents both personal injury and damage to the machine.

en-GB

11 276 280/08

United Kingdom

Miele Co. Ltd., Fairacres, Marcham Road
Abingdon, Oxon, OX14 1TW
Professional Sales, Tel: 0845 365 6608
E-mail: professional@miele.co.uk
Internet: www.miele.co.uk/professional

Australia

Miele Australia Pty. Ltd.
ACN 005 635 398, ABN 96 005 635 398
Level 4, 141 Camberwell Road, Hawthorn East, VIC 3123
Tel: 1300 731 411
Internet: www.miele.com.au/professional
E-mail: professional.sales@miele.com.au

China Mainland

Miele Electrical Appliances Co., Ltd.
1-3 Floor, No. 82 Shi Men Yi Road
Jing' an District, 200040 Shanghai, PRC
Tel: +86 21 6157 3500, Fax: +86 21 6157 3511
E-mail: info@miele.cn, Internet: www.miele.cn

Hong Kong, China

Miele (Hong Kong) Ltd.
41/F - 4101, Manhattan Place
23 Wang Tai Road, Kowloon Bay, Hong Kong
Tel: (852) 2610 1025, Fax: (852) 3579 1404
Email: customerservices@miele.com.hk
Website: www.miele.hk

India

Miele India Pvt. Ltd.
1st Floor, Copia Corporate Suites,
Commercial Plot 9, Mathura Road, Jasola,
New Delhi - 110025
E-mail: customercare@miele.in, Website: www.miele.in

Ireland

Miele Ireland Ltd.
2024 Bianconi Ave., Citywest Business Campus, Dublin 24
Tel: (01) 461 07 10, Fax: (01) 461 07 97
E-Mail: info@miele.ie, Internet: www.miele.ie

Malaysia

Miele Sdn Bhd
Suite 12-2, Level 12
Menara Sapura Kencana Petroleum
Solaris Dutamas No. 1, Jalan Dutamas 1
50480 Kuala Lumpur, Malaysia
Phone: +603-6209-0288
Fax: +603-6205-3768

New Zealand

Miele New Zealand Limited
IRD 98 463 631
8 College Hill
Freemans Bay, Auckland 1011, NZ
Tel: 0800 464 353
Internet: www.miele.com.au/professional
E-mail: professional.sales@miele.com.au

Singapore

Miele Pte. Ltd.
29 Media Circle, #11-04 ALICE@Mediapolis
Singapore 138565
Tel: +65 6735 1191, Fax: +65 6735 1161
E-Mail: info@miele.com.sg
Internet: www.miele.sg

South Africa

Miele (Pty) Ltd
63 Peter Place, Bryanston 2194
P.O. Box 69434, Bryanston 2021
Tel: (011) 875 9000, Fax: (011) 875 9035
E-mail: info@miele.co.za
Internet: www.miele.co.za



United Arab Emirates

Miele Appliances Ltd.
Showroom 1, Eiffel 1 Building
Sheikh Zayed Road, Umm Al Sheif
P.O. Box 114782 - Dubai
Tel. +971 4 3044 999, Fax. +971 4 3418 852
800-MIELE (64353)
E-Mail: info@miele.ae, Website: www.miele.ae



Manufacturer: Miele & Cie. KG
Carl-Miele-Straße 29, 33332 Gütersloh, Germany

Key:

	Connection required		Connection optional or required, depending on model
DV	Drain valve	KW	Cold water connection
AW	Drain connection	DP	Drain pump
B	Machine anchoring	PA	Equipotential bonding
DOS	Dispenser connection	SLA	Peak-load connection
EL	Electrical connection	APCL SST	Box plinth
F	Machine feet, adjustable	APCL OB	Open plinth
KG	Payment system	APCL 001	Washer-dryer stacking kit
KGA	Payment system connection	WW	Hot water connection
		XKM	Communication module

All rights reserved.

Appliance dimensions

* The distances between the machine and the wall are recommendations to help make it easier to carry out service work. If installation space is limited, the machine can also be pushed up against the wall.

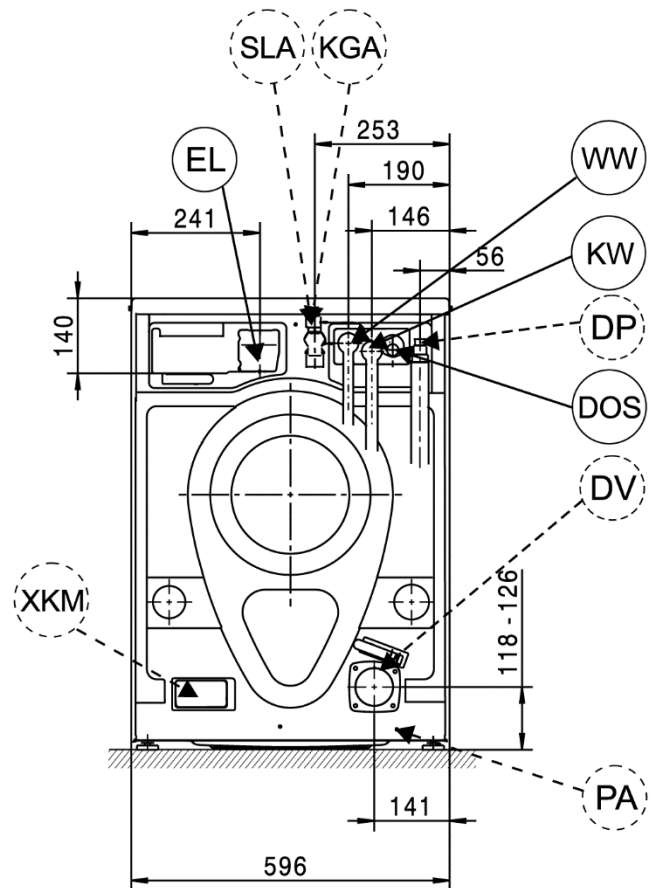
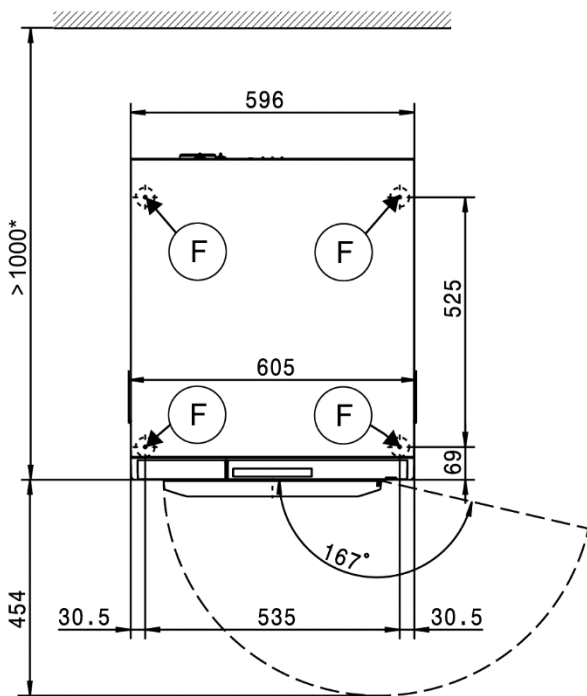
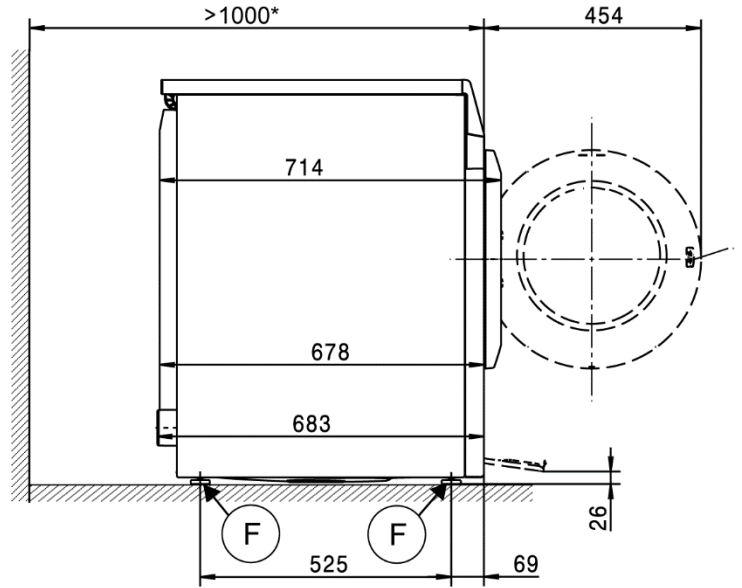
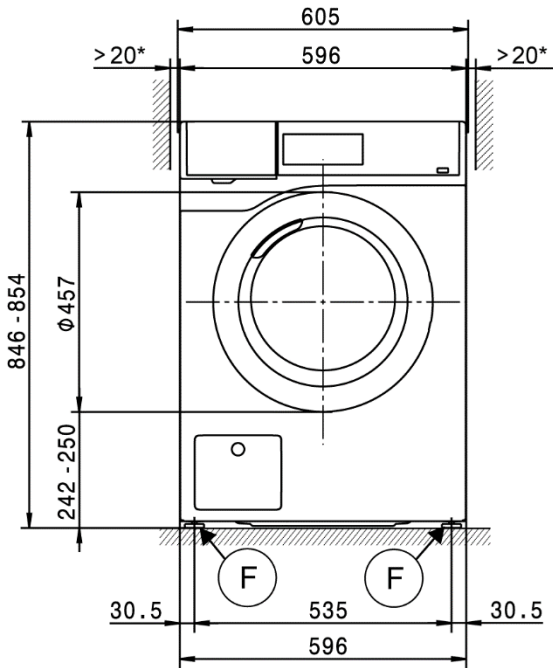

Installation

* The distances between the machine and the wall are recommendations to help make it easier to carry out service work. If installation space is limited, the machine can also be pushed up against the wall.

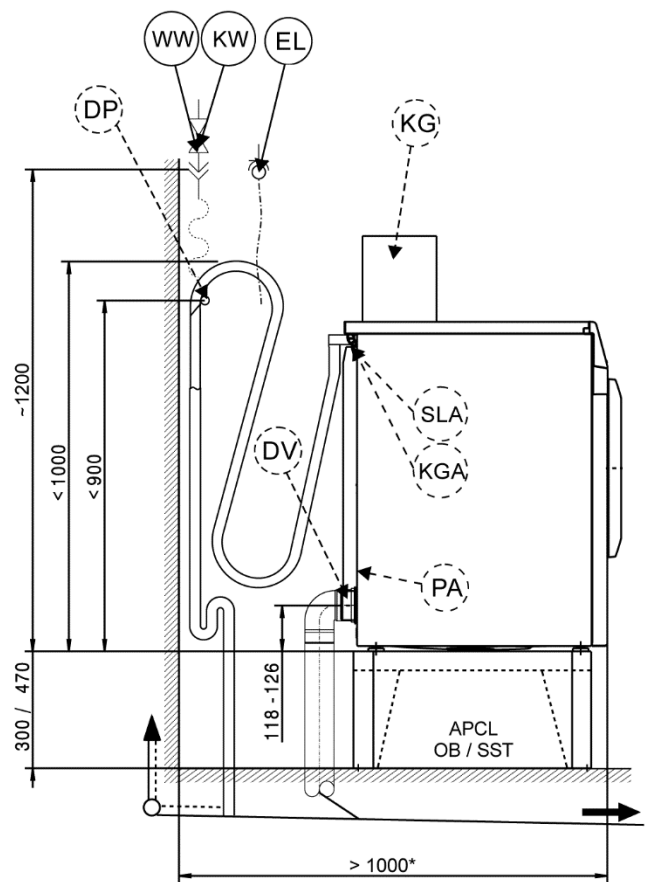
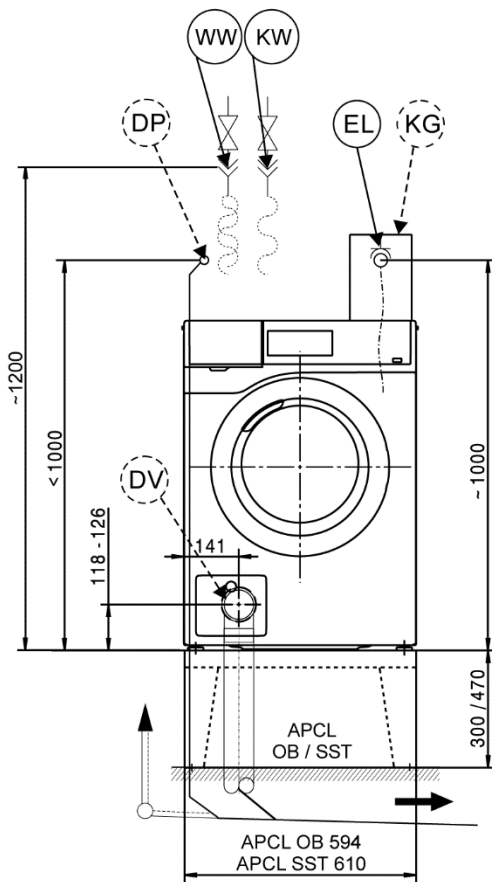
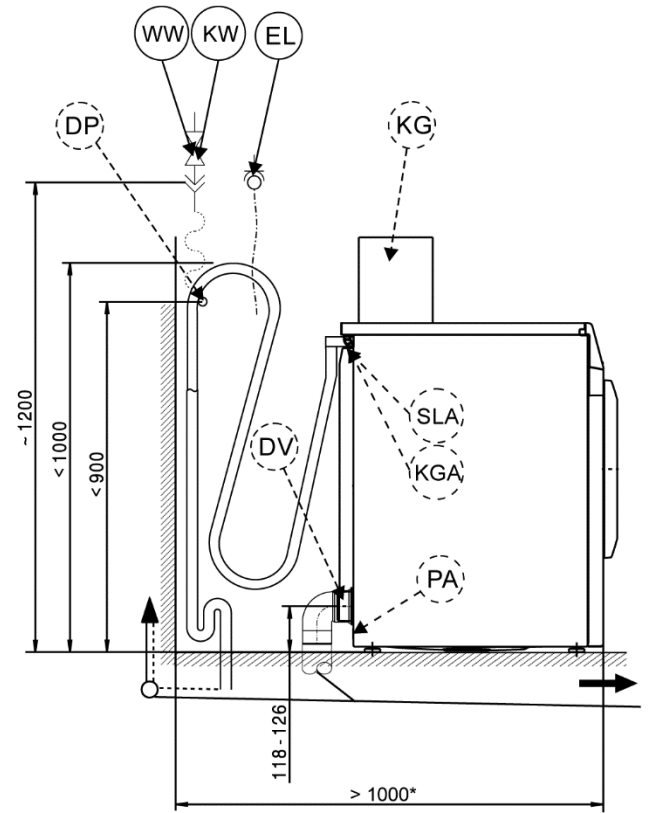
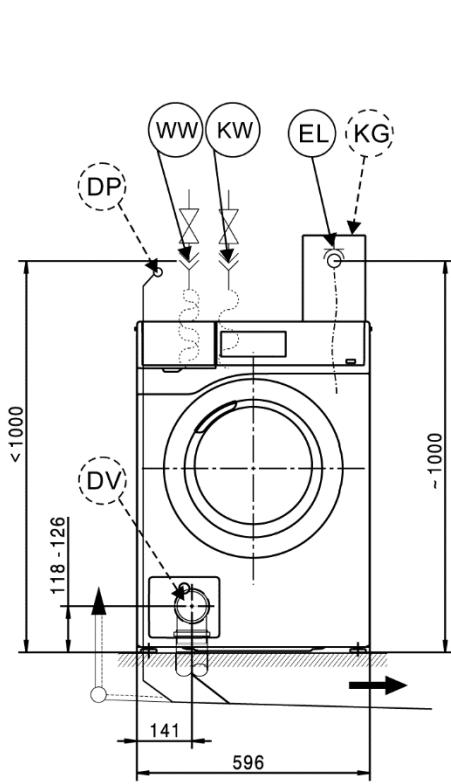

Washer-dryer stack

* The distances between the machine and the wall are recommendations to help make it easier to carry out service work. If installation space is limited, the machine can also be pushed up against the wall.

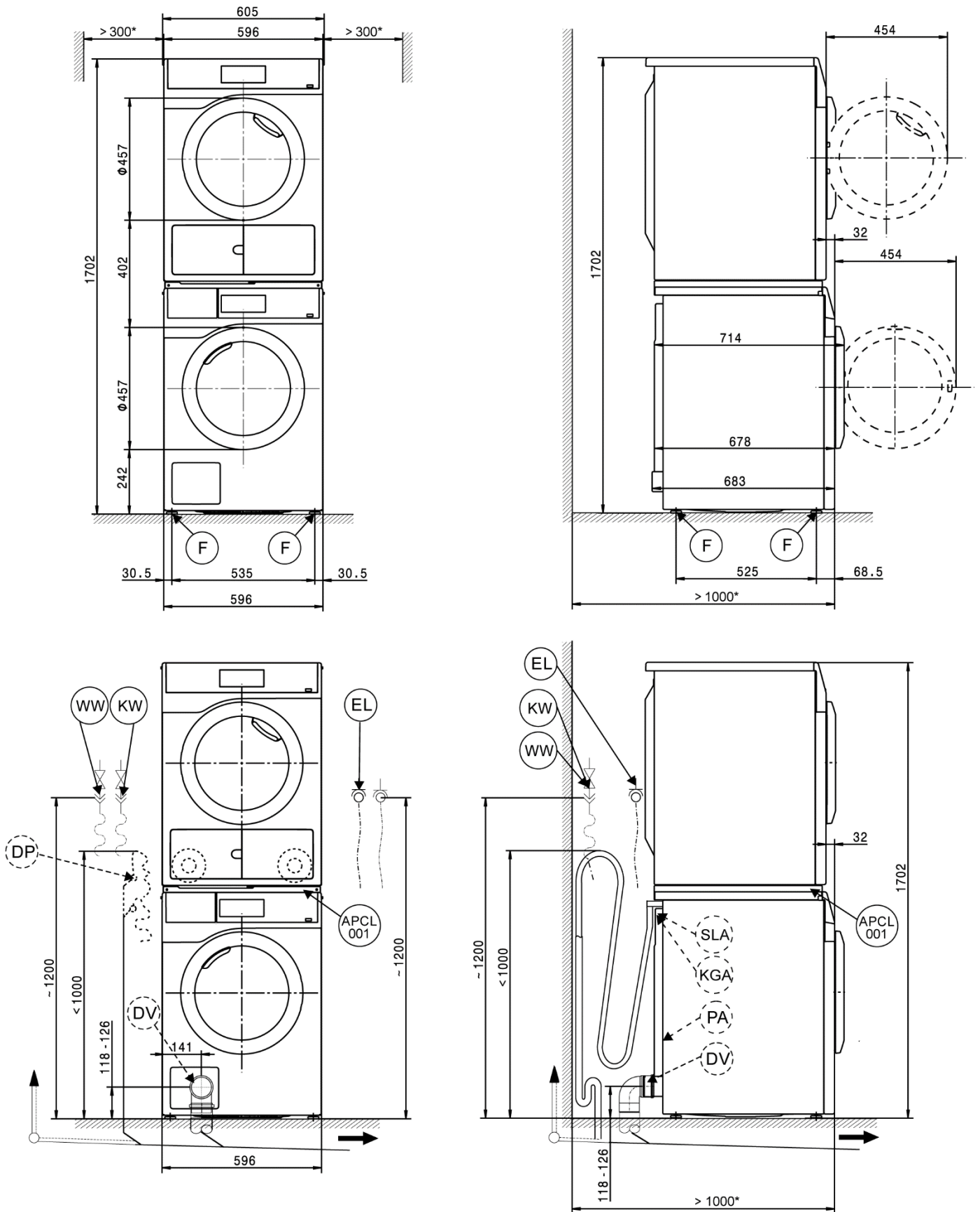

Installation

* The distances between the machine and the wall are recommendations to help make it easier to carry out service work. If installation space is limited, the machine can also be pushed up against the wall.

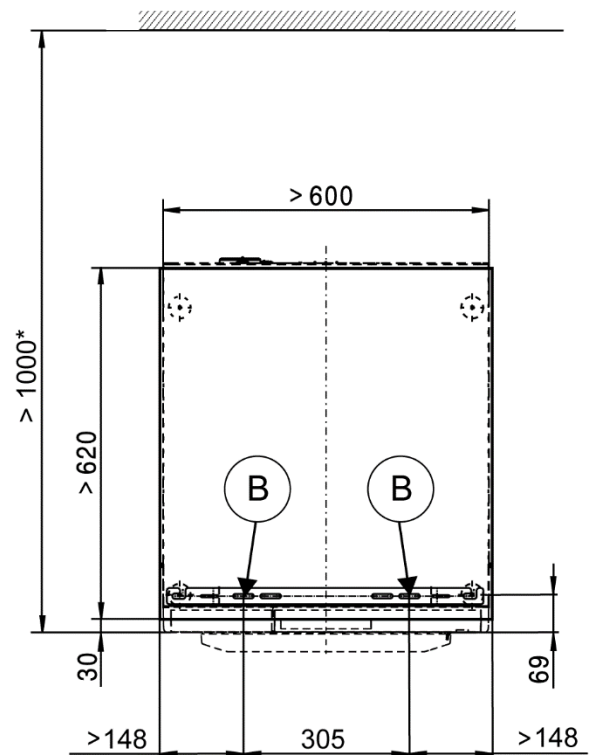
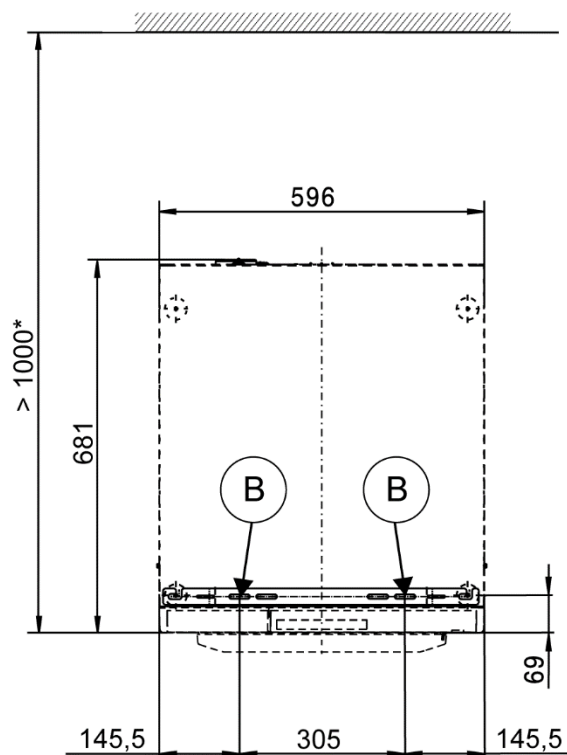
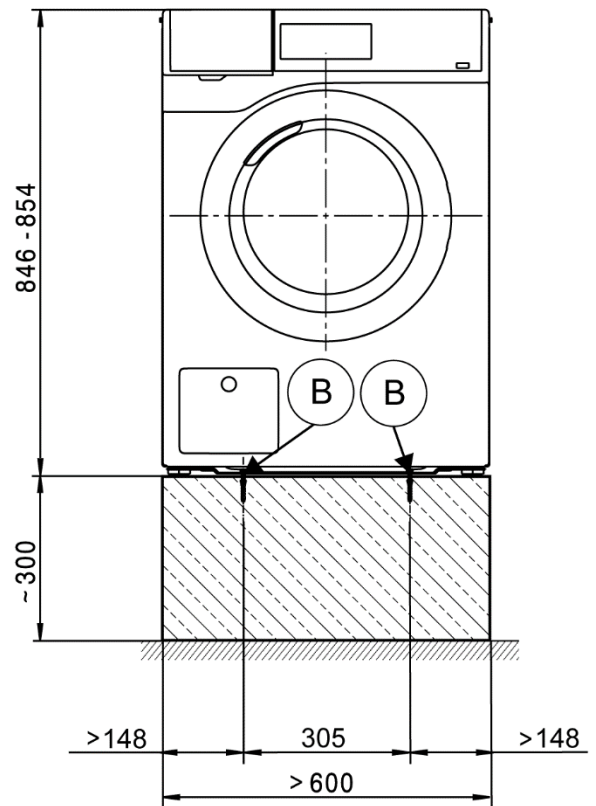
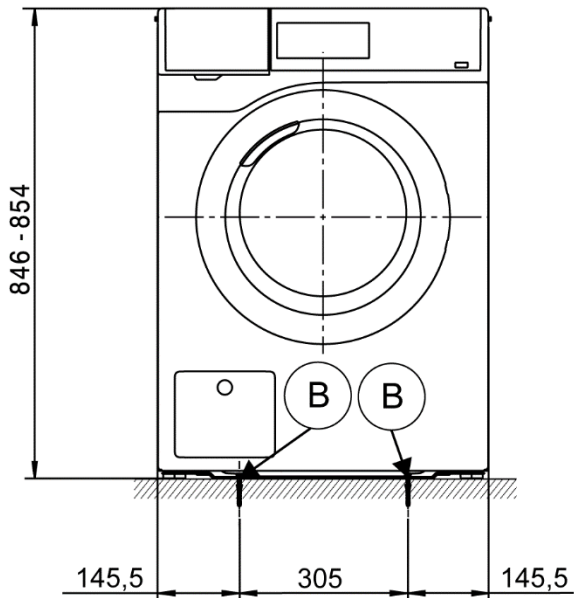

Installation

* The distances between the machine and the wall are recommendations to help make it easier to carry out service work. If installation space is limited, the machine can also be pushed up against the wall.

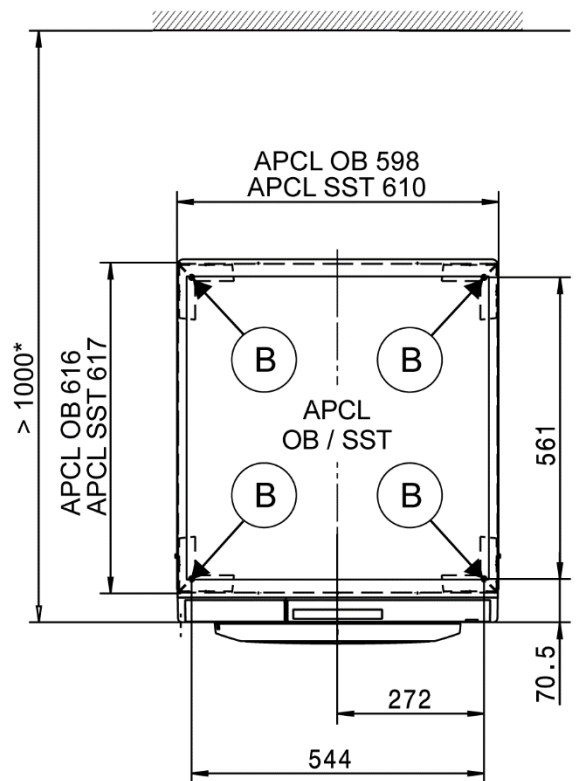
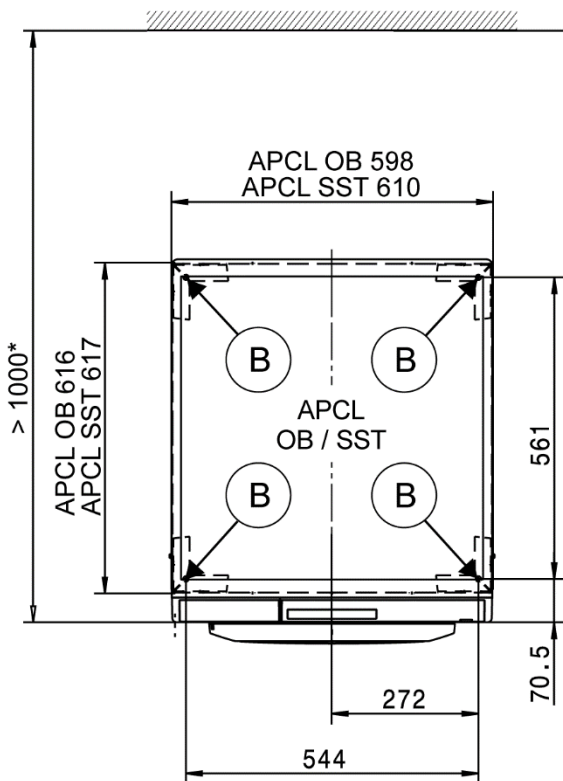
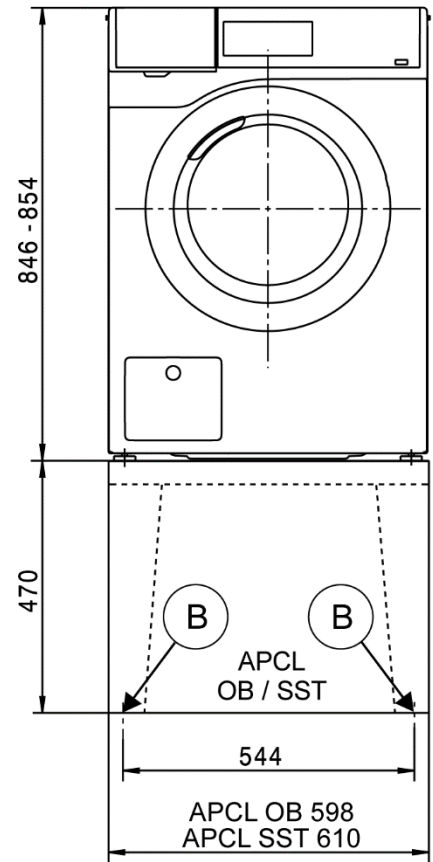
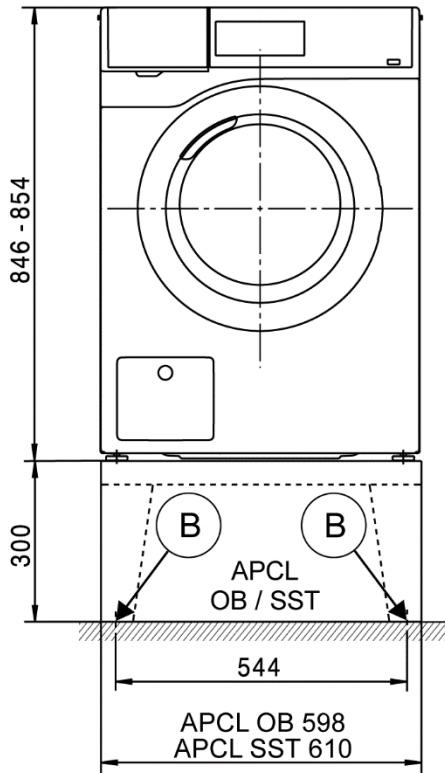

Technical data

		PWM 507 DV	PWM 507 DP	PWM 507 DV Hygiene/Special	PWM 507 DP Hygiene/Special
Drum volume	l	64	64	64	64
Load capacity	kg	7.0	7.0	7.0	7.0
Door opening diameter	mm	300	300	300	300
Max. spin speed	rpm	1600	1600	1600	1600
g-factor		704	704	704	704
Residual moisture (standard load per DIN 60456)	%	48	48	48	48

Electrical connection (EL)

Standard voltage		2N AC 400 V	2N AC 400 V	2N AC 400 V	2N AC 400 V
Frequency	Hz	50	50	50	50
Total rated load	kW	5.5	5.5	5.5	5.5
Fuse rating (B trip rating according to EN 60898)	A	2 x 16	2 x 16	2 x 16	2 x 16
Supply lead min. cross-section	mm ²	4 x 1.5	4 x 1.5	4 x 1.5	4 x 1.5
Supply lead without plug		●	●	●	●
Length of supply lead	mm	2000	2000	2000	2000

Alternative voltage (convertible by Service)		1N AC 230 V	1N AC 230 V	1N AC 230 V	1N AC 230 V
Total rated load	kW	2.85	2.85	2.85	2.85
Fuse rating (B trip rating according to EN 60898)	A	1 x 16	1 x 16	1 x 16	1 x 16
Supply lead min. cross-section	mm ²	3 x 1.5	3 x 1.5	3 x 1.5	3 x 1.5

Non-standard voltages MAR 400/440/480 (Marine)		3 AC 400/440/480 V
Frequency	Hz	50/60
Total rated load	kW	3.6/4.2/5.0
Fuse rating (B trip rating according to EN 60898)	A	3 x 16
Supply lead min. cross-section	mm ²	4 x 1.5
Supply lead without plug		●
Length of supply lead	mm	2000

Non-standard voltage MAR 230 (Marine)		1N AC 230 V
Frequency	Hz	60
Total rated load	kW	2.85
Fuse rating (B trip rating according to EN 60898)	A	1 x 16
Supply lead min. cross-section	mm ²	3 x 1.5
Supply lead with plug		●
Length of supply lead	mm	2000

Variations in the following countries:

Standard voltage 13 A (GB only)		2N AC 400 V	2N AC 400 V	2N AC 400 V	2N AC 400 V
Frequency	Hz	50	50	50	50
Total rated load	kW	5.5	5.5	5.5	5.5
Fuse rating (B trip rating according to EN 60898)	A	2 x 13	2 x 13	2 x 13	2 x 13
Supply lead min. cross-section	mm ²	4 x 1.5	4 x 1.5	4 x 1.5	4 x 1.5
Supply lead without plug		●	●	●	●
Length of supply lead	mm	2000	2000	2000	2000

Alternative voltage (convertible)		1N AC 230 V	1N AC 230 V	1N AC 230 V	1N AC 230 V
Total rated load	kW	2.85	2.85	2.85	2.85
Fuse rating (B trip rating according to EN 60898)	A	1 x 13	1 x 13	1 x 13	1 x 13
Supply lead min. cross-section	mm ²	3 x 1.5	3 x 1.5	3 x 1.5	3 x 1.5

Standard voltage 25 A (GB only)		1N AC 220–240 V	1N AC 220–240 V	1N AC 220–240 V	1N AC 220–240 V
Frequency	Hz	50	50	50	50
Total rated load	kW	5.05–6.0	5.05–6.0	5.05–6.0	5.05–6.0
Fuse rating (B trip rating according to EN 60898)	A	1 x 25	1 x 25	1 x 25	1 x 25
Supply lead min. cross-section	mm ²	3 x 2.5	3 x 2.5	3 x 2.5	3 x 2.5
Supply lead without plug		●	●	●	●
Length of supply lead	mm	2000	2000	2000	2000

● = standard, ○ = optional, + = only on request, - not available

Technical data

		PWM 507 DV	PWM 507 DP	PWM 507 DV Hygiene/Special	PWM 507 DP Hygiene/Special
Standard voltage (CH, DK, S only)		3N AC 400 V	3N AC 400 V	3N AC 400 V	3N AC 400 V
Frequency	Hz	50	50	50	50
Total rated load	kW	4.8	4.8	4.8	4.8
Fuse rating (B trip rating according to EN 60898)	A	3 x 10	3 x 10	3 x 10	3 x 10
Supply lead min. cross-section	mm ²	5 x 1.5	5 x 1.5	5 x 1.5	5 x 1.5
Supply lead without plug		●	●	●	●
Length of supply lead	mm	2000	2000	2000	2000
Standard voltage (B only)		2N AC 400 V	2N AC 400 V	2N AC 400 V	2N AC 400 V
Frequency	Hz	50	50	50	50
Total rated load	kW	5.5	5.5	5.5	5.5
Fuse rating (B trip rating according to EN 60898)	A	2 x 16	2 x 16	2 x 16	2 x 16
Supply lead min. cross-section	mm ²	4 x 2.5	4 x 2.5	4 x 2.5	4 x 2.5
Supply lead without plug		●	●	●	●
Length of supply lead	mm	2000	2000	2000	2000
Alternative voltage (convertible)		3 AC 230 V	3 AC 230 V	3 AC 230 V	3 AC 230 V
Total rated load	kW	5.5	5.5	5.5	5.5
Fuse rating (B trip rating according to EN 60898)	A	3 x 20	3 x 20	3 x 20	3 x 20
Supply lead min. cross-section	mm ²	4 x 2.5	4 x 2.5	4 x 2.5	4 x 2.5
Alternative voltage (convertible)		1N AC 230 V	1N AC 230 V	1N AC 230 V	1N AC 230 V
Total rated load	kW	2.85	2.85	2.85	2.85
Fuse rating (B trip rating according to EN 60898)	A	1 x 16	1 x 16	1 x 16	1 x 16
Supply lead min. cross-section	mm ²	3 x 1.5	3 x 1.5	3 x 1.5	3 x 1.5
Standard voltage (N only)		1N AC 230 V	1N AC 230 V	1N AC 230 V	1N AC 230 V
Frequency	Hz	50	50	50	50
Total rated load	kW	2.85	2.85	2.85	2.85
Fuse rating (B trip rating according to EN 60898)	A	1 x 16	1 x 16	1 x 16	1 x 16
Supply lead min. cross-section	mm ²	3 x 1.5	3 x 1.5	3 x 1.5	3 x 1.5
Supply lead with plug		●	●	●	●
Length of supply lead	mm	2000	2000	2000	2000
Alternative voltage (convertible)		3 AC 230 V	3 AC 230 V	3 AC 230 V	3 AC 230 V
Total rated load	kW	5.5	5.5	5.5	5.5
Fuse rating (B trip rating according to EN 60898)	A	3 x 20	3 x 20	3 x 20	3 x 20
Supply lead min. cross-section	mm ²	4 x 2.5	4 x 2.5	4 x 2.5	4 x 2.5
Alternative voltage (convertible)		2N AC 400 V	2N AC 400 V	2N AC 400 V	2N AC 400 V
Total rated load	kW	5.5	5.5	5.5	5.5
Fuse rating (B trip rating according to EN 60898)	A	2 x 16	2 x 16	2 x 16	2 x 16
Supply lead min. cross-section	mm ²	4 x 1.5	4 x 1.5	4 x 1.5	4 x 1.5
Standard voltage (AUS only)		1N AC 230 V	1N AC 230 V	1N AC 230 V	1N AC 230 V
Frequency	Hz	50	50	50	50
Total rated load	kW	5.5	5.5	5.5	5.5
Fuse rating	A	1 x 25	1 x 25	1 x 25	1 x 25
Supply lead min. cross-section	mm ²	3 x 2.5	3 x 2.5	3 x 2.5	3 x 2.5
Supply lead without plug		●	●	●	●
Length of supply lead	mm	2000	2000	2000	2000
Alternative voltage		1N AC 230 V	1N AC 230 V	1N AC 230 V	1N AC 230 V
Frequency	Hz	50	50	50	50
Total rated load	kW	2.85	2.85	2.85	2.85
Fuse rating	A	1 x 16	1 x 16	1 x 16	1 x 16
Supply lead min. cross-section	mm ²	3 x 1.5	3 x 1.5	3 x 1.5	3 x 1.5
Supply lead with plug		●	●	●	●
Length of supply lead	mm	2000	2000	2000	2000

● = standard, ○ = optional, + = only on request, - = not available

Technical data

		PWM 507 DV	PWM 507 DP	PWM 507 DV Hygiene/Special	PWM 507 DP Hygiene/Special
Cold water (KW)					
Permissible water flow pressure	kPa	100–1000	100–1000	100–1000	100–1000
Required flow rate (cold water connection only)	l/min	11	11	11	11
Required flow rate (with additional hot water connection)	l/min	10	10	10	10
Average water consumption (60 °C standard programme)	l/h	40	40	40	40
Connection to be provided on site, external thread according to DIN 44991 (flat seal)	Inch	¾"	¾"	¾"	¾"
Connection hose ½" with ¾" threaded union		●	●	●	●
Connection hose length	mm	1550	1550	1550	1550
Hot water (WW)					
Max. water intake temperature	°C	60	60	60	60
Permissible water flow pressure	kPa	100–1000	100–1000	100–1000	100–1000
Required flow rate	l/min	11	11	11	11
Average water consumption (60 °C standard programme)	l/h	13	13	13	13
Connection to be provided on site, external thread according to DIN 44991 (flat seal)	Inch	¾"	¾"	¾"	¾"
Connection hose ½" with ¾" threaded union		●	●	●	●
Connection hose length	mm	1550	1550	1550	1550
Drain valve (DV)					
Connection (ext. diameter)	mm	75 (DN 70)	-	75 (DN 70)	-
Max. drainage temperature	°C	90		90	
Max. transient flow rate	l/min	62	-	62	-
Drain pump (DP)					
Hose connection (external diameter)	mm	-	22 (DN 22)	-	22 (DN 22)
Max. drainage temperature	°C	-	90	-	90
On-site hose sleeve (int. diameter x length)	mm	-	22 x 30	-	22 x 30
Max. transient flow rate	l/min	-	26	-	26
Max. delivery head (from lower edge of machine)	mm	-	1000	-	1000
Drain hose DN 22 with connector (supplied as standard)		-	●	-	●
Connection hose length	mm	-	1500	-	1500
Equipotential bonding (PA)					
Machine connection (separate kit required)		○	○	○	○
XCI-Box / XCI-AD interface					
		●	●	●	●
Peak load/energy management (SLA)					
Machine connection (with XCI-Box)		○	○	○	○
Payment system connection (KGA)					
Connection of payment systems (with XCI-Box / XCI-AD)		○	○	○	○
Communication module (XKM)					
Communication module XKM 3200 WL PLT		○	○	○	○
Liquid dispensing (DOS)					
Connection for liquid detergents (conversion kit required)		-	-	-	-
Connection for liquid detergents		●	●	●	●
Max. no. of dispenser pumps	No.	6	6	6	6
XCI-Box interface		○	○	○	○
Installation on machine feet (F)					
No. of machine feet	No.	4	4	4	4
Machine foot, height-adjustable with thread	mm	+8	+8	+8	+8
Diameter of machine feet	mm	40	40	40	40

● = standard, ○ = optional, + = only on request, - = not available

Technical data

		PWM 507 DV	PWM 507 DP	PWM 507 DV Hygiene/Special	PWM 507 DP Hygiene/Special
Anchoring (B)					
Standard anchoring					
Floor anchor kit (for 2 machine feet) with anchors		●	●	●	●
Wood screws according to DIN 571	mm	6 x 50	6 x 50	6 x 50	6 x 50
Rawl plugs (diameter x length)	mm	8 x 40	8 x 40	8 x 40	8 x 40
Anchoring of Miele plinths					
Accessory: Miele plinth (fasteners included)		○	○	○	○
Required anchor points	No.	4	4	4	4
Wood screws according to DIN 571	mm	8 x 65	8 x 65	8 x 65	8 x 65
Rawl plugs (diameter x length)	mm	12 x 60	12 x 60	12 x 60	12 x 60
Plinth floor anchoring (to be provided on site)					
Machine installation on permanent plinth (concrete or masonry)		○	○	○	○
Plinth installation footprint (W/D)	mm	600/650	600/650	600/650	600/650
Wood screws according to DIN 571	mm	6 x 50	6 x 50	6 x 50	6 x 50
Rawl plugs (diameter x length)	mm	8 x 40	8 x 40	8 x 40	8 x 40
Machine data					
Overall machine dimensions (H/W/D)	mm	850/605/714	850/605/714	850/605/714	850/605/714
Casing dimensions (H/W/D)	mm	850/596/678	850/596/678	850/596/678	850/596/678
Site-access dimensions (H/W)					
Min. site-access (excl. packaging)	mm	900/605	900/605	900/605	900/605
Installation dimensions					
Side gap	mm	20	20	20	20
Recommended side gap – washer-dryer stack	mm	300	300	300	300
Recommended distance to opposite wall from machine front	mm	1000	1000	1000	1000
Weights and floor loads					
Machine weight (net weight)	kg	100	100	100	100
Max. floor load in operation	N	2820	2820	2820	2820
Max. floor load, static	N	1380	1380	1455	1455
Max. floor load, dynamic	N	1365	1365	1365	1365
Emissions					
Sound pressure level (in accordance with EN ISO 11204/11203)	dB(A)	<70	<70	<70	<70
Heat dissipation rate to installation site	W	250	250	250	250

● = standard, ○ = optional, + = only on request, - = not available

Installation and planning notes

Installation requirements

Electrical connection should only be made to a power supply provided in accordance with all appropriate local and national legislation and regulations.

In addition, all regulations issued by the appropriate utilities as well as standards relating to occupational safety, and all applicable valid regulations and technical standards must be observed!

Transportation and site access

The washing machine must not be moved without the transit bars in place. Keep the transit bars in a safe place. They must be re-fitted if the machine is to be moved again (e.g. when relocating the machine).

General operating conditions

Ambient temperature in installation room: +2 °C to +35 °C.

Depending on the nature of the installation site, sound emissions and vibration may occur. Miele recommends consulting a specialist if particular requirements apply at the installation site with respect to sound emissions.

Electrical connection

Depending on the model, the machine is delivered with a supply lead with/without a plug.

The appliance may only be connected to an electrical system that conforms to the national and local codes and regulations (BS 7671 in the UK). The installation must be performed by a qualified electrician.

The data plate indicates the nominal power consumption and the appropriate fuse rating. Compare the specifications on the data plate with those of the electrical power supply.

It is always recommended to make electrical connection via a plug and socket so that electrical safety checks, e.g. during repair or service work, can be carried out easily.

The machine can be hard-wired or connected using a switched connection in accordance with IEC 60309-1. If the machine is hard wired, a dual circuit breaker must be provided on-site. When switched off there must be an all-pole contact gap of at least 3 mm in the isolator switch (including circuit breaker, switch, fuses and relays according to IEC/EN 60947).

The plug connector or isolator switch should be easily accessible at all times. If the machine is disconnected from the electricity supply, the isolator must be lockable or the point of disconnection must be monitored at all times.

New connections, modifications to the system or servicing of the ground conductor, including determining the correct fuse amperage, must be carried out by a qualified electrician, as they are familiar with the pertinent regulations and the specific requirements of the electric utility company.

If converting the appliance to an alternative voltage, observe the instructions in the wiring diagram. Conversion must be performed by the Miele Customer Service Department or by an authorised service technician. The heater rating must also be adapted.

The washing machine should be connected directly to an electrical supply outlet. The use of extension leads to power the washing machine is not permitted and must not be used.

References to cable cross-sections in the technical data refer only to the required supply lead. Please consult relevant local and national regulations when calculating any other wire gauges.

For installation in GB

Both the hot and cold water hose must be connected to the mains water supply with the use of the provided double check valves.

Cold water connection

The washing machine should be connected to a mains water supply in accordance with current local and national safety regulations. The German authorities do not require it to have a non-return valve as the washing machine has been designed to comply with current local and national regulations on water safety.

Connection to the water supply should be carried out by a qualified plumber using a stopcock with a threaded union. If a stopcock is not available, a qualified plumber should connect the machine to the water supply.

A suitable connection hose with a threaded union is provided with the appliance.

Longer hoses (2.5 or 4.0 m in length) are available from your Miele dealer or the Miele Customer Service Department as separate items.

Hot water connection

The same connection requirements as for cold water also apply to hot water (max. 60 °C).

A suitable connection hose with a threaded union is provided with the appliance.

The hot water connection appliance also requires a cold water connection.

In the event that hot water is not available on site, connection of the second hose must be made to a cold water supply.

Alternatively, the hot water connection should be blocked using the enclosed blind stopper and the machine controls set to cold water intake.

The required amount of hot water should be added to the cold water volume.

Drain valve (depending on model)

The machine is drained using a motorised drain valve. The machine can be connected directly to the on-site drainage system (without a siphon) or via a floor drain (gully with odour trap).

A vented drainage system is vital for unimpeded drainage. If on-site venting is insufficient, a vent kit (Mat. no. 05 239 540) is available from your Miele dealer or the Miele Customer Service Department.

If several machines are connected to a single drain pipe, this should be sufficiently large to allow all machines to drain simultaneously.

Drain pump (depending on model)

The suds are drained through a drain pump with a 1 m delivery head. For the water to drain freely, the hose must be free of kinks.

Drainage options:

1. Connected securely to a plastic drain pipe with a rubber sleeve. There is no need for a siphon.
2. Connected securely to a washbasin with a plastic nipple.
3. Connected securely to a floor drain (gully).

Securely connect the drain hose to a sink drain outlet

The drain hose can be connected securely to a suitable sink drain outlet.

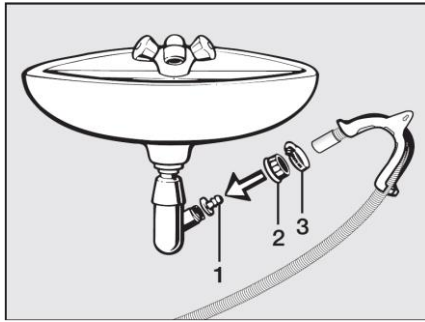

If required, the hose can be extended to a length of up to 5 m. Accessories are available from the Miele Customer Service Department or from your Miele dealer.

For a delivery head of more than 1 m (up to a max. of 1.6 m), a replacement drain pump is available from the Miele Customer Service Department or from your Miele dealer.

Equipotential bonding

If necessary, equipotential bonding with good galvanic contact must be guaranteed in compliance with all applicable local and national installation specifications.

Connection material for equipotential bonding must be provided on site or using a kit available from the Miele Customer Service Department.

Peak load / energy management

The appliance can be connected to a peak-load or energy management system using an optional kit.

When the peak-load function is activated, the heating is deactivated. An appropriate message appears in the display.

Liquid dispensing connection

External liquid dispenser pumps with a "container empty" indicator can be used to dispense liquid detergents.

The dispenser pumps can only be programmed with MDU.

It is particularly important to observe manufacturer's instructions when using a combination of detergents, additives and special-purpose products.

Payment system

This washing machine can be fitted with a single-machine payment system as an optional accessory using an optional kit (XCI-Box / XCI-AD).

The programming required for connecting a payment system can be carried out during the initial commissioning process. After initial commissioning, changes may only be carried out by your Miele dealer or the Miele Customer Service Department.

Interface

The appliance can be fitted with an XKM 3200 WL PLT communication module. This module can be used as a WiFi or LAN interface.

The LAN interface provided via the module complies with SELV (Safety Extra Low Voltage) in accordance with EN 60950. Connected appliances must also comply with SELV. The LAN connection uses a RJ45 connector in accordance with EIA/TIA 568-B.

Installation

The machine must be installed on a perfectly smooth, level and firm surface which is able to withstand the quoted loads.

The floor load created by the machine is concentrated and transferred to the installation footprint via the machine feet.

The machine should be levelled in both directions with the aid of the adjustable feet.

Plinth installation

The washing machine can be installed on a machine plinth (open or box plinth, available as an optional Miele accessory) or on a concrete plinth to be provided on site.

The quality of the concrete and its strength must be assessed according to the machine load. Ensure that any raised concrete plinth is adequately bonded to the concrete floor below!

If the washing machine is installed on a concrete or masonry plinth, it must be secured using the anchors supplied with the machine. Otherwise, there is the danger of the washing machine moving about during spinning and falling off a plinth.

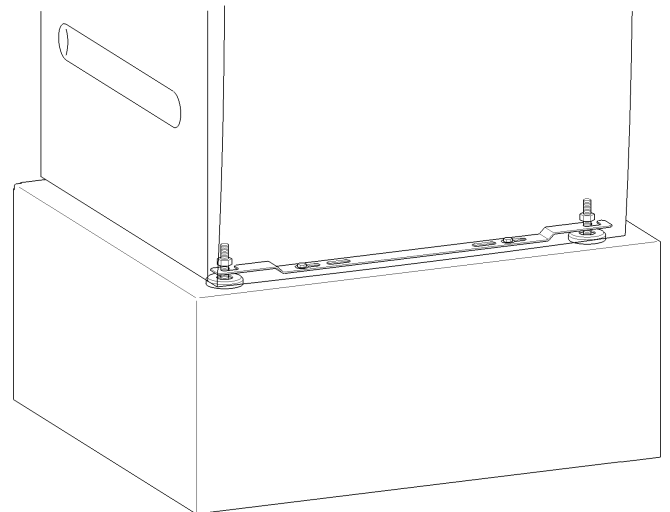

The anchors provided can be used to bolt the machine to the floor by both front feet. The material provided is intended for use in bolting the machine to a concrete floor.

Washer-dryer stack

The washing machine can be installed as a washer-dryer stack together with a Miele tumble dryer. A stacking kit (optional accessory) is required for this.

Installation of the stacking kit must be performed by the Miele Customer Service Department or an authorised Miele service technician.